

SIG-LITE INSTALLATION & OPERATION MANUAL



WARNING: Read the entire manual before installing or operating this Sigalarm product. Failure to follow these instructions and safety precautions could result in serious injury or death. Keep this manual near the equipment where SIG-LITE has been installed.

TABLE OF CONTENTS

Important Safety Notice	4
Intended Uses & Limitations	4-5
Glossary	6-7
I. OVERVIEW	8
1.1 General Description	8
1.2 Understanding E-Field Detection	8
1.3 Safety Warnings	9
1.4 Safety Regulations	9
2. INSTALLATION	10
2.1 Standard Packing List	10
2.2 Installation Precautions	10
2.3 Installation of the Control Module	10
2.4 Connecting to a Power Source/Relay Options	11
2.5 Installation of the Sensor(s)	12
2.6 Installation of the External Speaker	14
2.7 Testing the Installation	14
2.8 Key Features	15
3. MENU DISPLAY IDENTIFICATION	16
3.1 Internal Speaker	16
3.2 Distribution Line Graphic	15
3.3 Distribution Line Button	15
3.4 Distribution LED Indicator	15
3.5 Sub-Transmission Graphic	15
3.6 Sub-Transmission Button	15
3.7 Sub-Transmission LED indicator	15
3.8 Sensor Status LED Indicator	15
3.9 Resume Operation Button	15
3.10 LED Bar Display Indicates the AC Field	15
3.11 Side Port Access	15

TABLE OF CONTENTS

3.11.1 Sync button	15
3.11.2 USB Programming Port	15
3.11.3 Micro SD Card Slot	15
4. OPERATION	17
4.1 Warnings	17
4.2 Powering Up	17
4.3 Know Mad Distance	17
4.4 Changing between set points	17
4.5 Operating distribution setting	17
4.6 Operating Sub-Transmission Setting	17
4.7 Operating with a Caution	18
4.8 Operating with a Warning	18
4.9 Sensor Status LED	18
4.10 Volume Adjustment	18
4.11 Operating with Auto Shutdown Installed	18
4.12 Resume Movement	19
4.13 Operating Near Intersecting Power Lines	19
5. SPECIFICATIONS	20
6. TROUBLESHOOTING	21
7. FCC COMPLIANCE STATEMENT	22
8. CANADIAN COMPLIANCE STATEMENT	23
9. RELAY OUTPUTS DIAGRAM	24
10. SENSOR SELF-TEST PROCEDURE	25

Information furnished by Allied Safety Systems Inc. DBA Sigalarm in this document is believed to be accurate. Allied Safety Systems Inc. makes no warranty, express, statutory and implied or by description, regarding the information set forth herein. Allied Safety Systems Inc. reserves the right to change specifications at any time and without notice.

Allied Safety Systems Inc. reserves the right to make periodic modifications of this product without obligation to notify any person or entity of such revision. Copying, duplicating, selling, or otherwise distributing any part of this manual without the prior consent of an authorized representative of Allied Safety Systems Inc. is prohibited.

IMPORTANT SAFETY NOTICE

To minimize the risk of serious injury or death, operators of Sigalarm products agree to the following:

- ▶ Sigalarm products should only be installed by a Sigalarm distributor, qualified installer, or qualified personnel.
- ▶ Operators should receive training prior to the use of Sigalarm products..
- ▶ Operators must read the SIG-LITE instruction manual prior to operation.
- ▶ Sigalarm products are an early warning device that notifies the operator that a sensor located on the machine is in close proximity to potentially dangerous overhead AC high voltage lines. Use of this device should not take the place of following safe operating procedures including visual observation of your closeness to power lines.
- ▶ Operators must use extreme care (and use a spotter) while operating this product. Operator must maintain a safe distance from power lines at all times.
- ▶ **IMPORTANT:** This product is designed to warn of an approximate distance or proximity to power lines. However, Sigalarm products should never be relied upon to provide a warning for equipment intentionally operating at less than 10ft from an energized power line.

If you have any questions or are unsure about how to operate this product, stop and contact your employer or Sigalarm immediately. Operations shall resume only after safety concerns have been addressed.

Important Safety Notice For Operators Of Vehicles & Equipment Equipped With A SIG-LITE High Voltage Power Line Warning System

Before operating this vehicle, operators must read the SIG-LITE Installation and Operation Manual that should be stored with the vehicle. If the manual is missing, go to www.sigalarminc.com or call SIGALARM at 1-800-589-3769 to get a replacement.

Operators should receive training prior to the use of SIGALARM products.

SIG-LITE is an early warning device that notifies the operator he/she is in close proximity to potentially dangerous overhead AC high voltage lines. Use of this device should not take the place of following safe operating procedures including visual observation of your proximity to power lines. SIGALARM products should never be relied upon for vehicles intentionally operating at less than 10 feet from an energized power line.

If the unit alarms with a yellow on the LED Bar, then the predetermined CAUTION threshold has been met. This means that the vehicle is close enough to power lines that there is a possibility of serious injury.

Red on the SIG-LITE LED Bar and audible alarm indicates that the DANGER threshold has been met. This means that the vehicle is close enough to power lines that there is a high probability that the operator or a bystander could suffer serious injury or death. Stop vehicle movement immediately.

IMPORTANT: DO NOT OPERATE THE VEHICLE IF THE "SENSOR STATUS" LED IS RED INDICATING THE WIRELESS SENSOR IS NOT DETECTED



INTENDED USES & LIMITATIONS

WARNING: Read this section and the IMPORTANT SAFETY NOTICE each time before using SIG-LITE. Using SIG-LITE for an unintended use or beyond its limitations can result in serious injury or death. Power line warning systems are a powerful operator aid. The intended use for power line warning systems is to detect the presence of an E-field to provide a warning of danger to the operator or bystanders.

Sigalarm products are intended for use in normal commercial and industrial applications. Applications where extreme temperature ranges or unusual environmental requirements exist such as military, medical life-support or life-sustaining equipment are specifically not allowed without additional testing for such application.

When OSHA regulations apply, they require the employer to determine the minimum approach distance (MAD) for safe use required for each job site. No operator should allow the equipment to be closer to the power line than the MAD. SIG-LITE should not be used to determine distance. Doing so is a misuse of the product and potentially very dangerous. The employer should always use a spotter to help determine the safe distance.

Sigalarm products **are not intended** to be used for the following:

- ▶ To measure distances from power lines.
- ▶ To detect DC power lines.
- ▶ To detect underground electrical sources.
- ▶ To provide warning closer than 10ft to a power line.
- ▶ To detect voltages that are less than 7,200v. Relying solely on Sigalarm power line warning systems to detect lower voltages may result in a warning when the equipment is too close to the power source and therefore potentially dangerous.
- ▶ To replace any other safety requirements.

WARNING: Using Sigalarm products for the above unintended uses is dangerous and could result in serious injury or death.

- ▶ ▶ ▶ If for any reason you do not believe the SIG-LITE unit is working correctly,

DO NOT OPERATE.

▶ ▶ ▶ SIG-LITE's accuracy could be adversely affected by such factors as:

1. Operating the equipment with a boom angle and length significantly different than that used for the device's last setpoint adjustment; and
2. Operating the equipment on sites with multiple overhead power lines, especially where those power lines had differing voltages or involve intersecting installation lines.

GLOSSARY

Audible Signal: A signal made by a distinct sound or series of sounds. Examples include, but are not limited to, sounds made by a bell, horn, or whistle.

Caution Status: Indication in yellow on SIG-LITE that the CAUTION threshold has been met. This means that the equipment is close enough to power lines that there is a possibility of serious injury.

Competent (Person): A person who is capable of identifying existing and predictable hazards in the surroundings or working conditions that are hazardous or dangerous to employees, and who has authorization to take prompt corrective measures to eliminate them.

Controller/Control module: User interface of the SIG-LITE power line warning system

Danger: Indication in red on SIG-LITE that the DANGER threshold has been met. This means that the equipment is close enough to power lines that there is a high probability that the operator or a bystander could suffer serious injury or death. Movement of the equipment must be stopped.

Dedicated Spotter (Power Lines): To be considered a dedicated spotter under OSHA regulations, the requirements of § 1926.1428 (Signal person qualifications) must be met and his/her sole responsibility is to watch the separation between the power line and the equipment, load line and load (including rigging and lifting accessories and ensure through communication with the operator that the applicable minimum approach distance(MAD) is not breached.

E-Field: A region around a charged particle where other charged particles experience a force. The strength of an electric field is measured in volts per meter. This is equivalent to newtons per coulomb (Force per charge). The relationship follows an inverse-square law, which means that the electric field strength is

proportional to the inverse of the square of the distance from the charge. The closer to a power line the higher the E-Field strength.

Encroachment: Where any part of the equipment (including rigging and lifting accessories) breaches a minimum clearance distance. For Example: Means “one example, although there are others.”

High Voltage: Measured voltage higher than 600 V ac.

Include/Including: Means “including, but not limited to.”

Limitation: Threshold, and parameters on both at which the high-voltage proximity alarm will not reliably function above or below, or both.

Minimum Approach Distance (MAD): defined in OSHA 29 CFR Part 1926 § 1926.1407- § 1926.1411.

SIG-LITE is a power line warning system: that provides a warning of general proximity to a power line. It is also referred to as a proximity warning device (PWD) and or High voltage proximity alarm (HVPA).

Range Control Limit Device: A device that can be set by an equipment operator to limit movement of the boom or jib tip to a plane or multiple planes.

Range Control Warning Device: A device that can be set by an equipment operator to warn that the boom or jib tip is at a plane or multiple planes.

Qualified Person: A person who, by possession of a recognized degree, certificate, or professional standing, or who by extensive knowledge, training and experience, successfully demonstrated the ability to solve/resolve problems relating to the subject matter, the work, or the project.

Sensor: A device that is used to detect the strength of an E-field in V/M

Sensor Status: Indicates the connection status of the sensor

Volt Per Meter: The standard unit of electric field (E field) strength. Symbolically, it is represented as V/m. An E field of 1 V/m refers to a potential difference of 1 V between two points 1 m apart.

WARNING (All Caps): When this word is used in this manual, it means that there is a moderate probability of serious injury or death if the instructions after this word are not followed.

Warning: An audible alarm from SIG-LITE indicating that the equipment being operated is in a dangerous location. The operator must stop immediately and reposition the equipment to a safe location.

I. OVERVIEW

I.1 GENERAL DESCRIPTION

Introducing SIG-LITE, a Power line warning Device (PWD) and risk management tool built on 50 years of proven reliability and dependability. Designed for rugged use worldwide in construction, mining, telecommunications, and the aerial lift rental market.

U.S. distribution power lines are generally classified between 7.2kV and 13.5kV and are estimated to account for over 96% of all overhead HV power lines in the U.S. The SIG-LITE unit will automatically default itself to warn of proximity to overhead distribution power lines. If work is required around higher voltage sub-transmission lines simply switch to the alternate sub-transmission setting pre-calibrated for these higher voltages. At any time, the operator can easily switch between alarm set points for a specific jobsite.

The SIG-LITE control module communicates with wireless E-field sensors and indicates proximity (closeness and nearness) to overhead HV lines. The high visibility LED bar showing yellow or red lights. in conjunction with the internal & external speakers, is activated when it is close to HV power lines.

I.2 UNDERSTANDING E-FIELD DETECTION

SIG-LITE is a reliable and finely tuned warning system designed to receive only one selective and potentially source: the detectible E-field present around all AC high-voltage power lines. SIG-LITE uses the science of E-field detection to provide equipment operators and ground personnel with a warning in time for them to avoid any hazardous situation.

The strength of the signal (E-field) depends on the lines' voltage and the distance from the lines. Visual and audible alarms will occur whenever the specified E-field (voltage V/m) is detected. **The goal is to always alert the operator of the proximity to danger in enough time to allow them to move away and prevent contact.** Therefore, Sigalarm warning systems are only recommended for equipment located 10ft or more from an AC overhead power line.

Sigalarm products do NOT measure distance. Determining the accurate distance from the Sigalarm to the AC overhead power line should be done by a dedicated spotter.

AC VOLTAGE DETECTION ONLY

Sigalarm products do NOT detect DC voltage.

I.3 SAFETY WARNINGS

Contact with overhead power lines are a constant danger to anyone working with or near equipment that are near these high-voltage lines. No warning device can absolutely prevent an accident. When properly installed and operated, Sigalarm products should provide reliable and repeatable WARNINGS of the presence of high voltage.

I.4 SAFETY REGULATIONS

It is the equipment operator's responsibility to know and follow all OSHA, employer, utility, and equipment manufacturers' safety instructions, rules, and regulations.

NOT A DISTANCE MEASURING DEVICE

Sigalarm products are warning systems and should not be used as distance measuring devices.

SCAN TO
DOWNLOAD
MANUAL



WARNING

VOLTAGE RANGE: THIS SYSTEM IS DESIGNED FOR DETECTING AC VOLTAGES OF 7,200V OR HIGHER AT APPROXIMATE DISTANCES OF 10FT-200FT. SIG-LITE SHOULD NOT BE RELIED UPON TO PROVIDE A WARNING FOR VOLTAGES LESS THAN 7,200V AC OR CLOSER THAN 10FT.

PRODUCT SIG-LITE
MODEL LITE- _____
SN _____

SIGALARMINC.COM
4150 ST. JOHNS PKWY, STE 1002
SANFORD, FL 32771
info@sigalarminc.com
(407) 321-0722
MADE IN USA

2. INSTALLATION

2.1 SINGLE SENSOR STANDARD PACKING LIST

Part #	QTY	DESCRIPTION
LITE-000	1	Controller/Control module
SPC-5P	1	External Speaker
WS4.0-SL	1	Sensor (s)
15-LEH	1	Cable harness
SL-Manual	1	Installation/Operation manual
7315-SL	1	Parts bag (Window sticker, Branding domed Sigalarm logo decal, Mounting screws, T25 tamper-resistant 1/4" bit)
RAM-B-101U	1	Standard Ram mount
WS4.0-SL	1	Sensor
WB3.0	1	Sensor cage guard (optional)
408-112-15U	1	RAM B MEWP rail mount (optional)
247U-15	1	RAM B MEWP square tube mount (optional)

2.2 INSTALLATION PRECAUTIONS

Sigalarm products may only be installed by a certified installer or qualified person. Prior to using Sigalarm products, the operator should be trained by a certified trainer or qualified person. Use extreme care and a spotter while testing this equipment.

2.3 INSTALLATION OF THE CONTROL MODULE

The main component of the SIG-LITE system is the control module. It should be mounted near the operator in plain view, without obstructing their view of the work area.

2.4 CONNECTING THE CONTROL MODULE TO A POWER SOURCE

Attach the supplied cable harness 15- LEH to a 12v to 30v DC power supply. The 15-LEH cable has a Grey jacket with 12 conductors and can be installed one of two ways. Direct or switched power.

PIN	COLOR	FUNCTION
1	Blue	Relay 1 NC
2	White/Back Stripe	Relay 1 NO
3	Red/Black Stripe	Relay 2 NC
4	Green/Black Stripe	Relay 2 NO
5	Orange/Black Stripe	Relay 2 COM
6	Blue/Black Stripe	Relay 1 COM
7	NOT USED	No wire
8	Black	Ground (Vehicle Chassis Common)
9	Orange/Black Stripe	Vehicle Power (Battery)
10	Red/Black Stripe	Vehicle Switched Power (Main Power)
11	White/Black Stripe	External Speaker Plus
12	Green/Black Stripe	External Speaker Minus

RELAY OUTPUTS

Relay 1 is intended to stop movement when AC is detected. Relay 1 is SET when the threshold for relay 1s setting is exceeded. The threshold is a configurable parameter (see section on settings). Relay 1 is RESET when the operator presses override.

Relay 2 is intended for external alerts such as a strobe light. Relay 2 is SET when the threshold is exceeded. The threshold is a configurable parameter (see section on settings). Relay 1 is RESET when the operator presses override.

NOTE: Relays can switch up to 1 Amp Current Max

2.5 INSTALLATION OF THE SENSORS

The solar sensors are the component of the system that detects voltage.

Use caution when opening sensor lids to avoid cable damage

I. TURN THE SENSOR ON:

Remove the sensor lid and put the switch SW1 in the on position

2. TO PAIR SENSOR(S):

Flashing blue LED on sensor indicates scanning mode available for two minutes. Pairing must be done within 2 minutes of turning on sensor or simply turn off and back on to enter pairing mode again. Up to 2 sensors can be paired to one SIG-LITE control unit.

- a. On the control module, remove the side access panel (T25 tamper resistant bit needed)
- b. Press and release the red pairing button (shown below).
 - i. The control panels LEDs will display yellow and start scanning indicating that the unit is in its pairing mode. Green LEDs shown here indicate the number of paired sensors
- c. Press the pairing button on the sensor within first two minutes of turning on sensor
- d. The control module will indicate pair is successful by with a single green LED lit.
- e. Press the pairing button on the sensor again to exit pairing mode or it will simply time out pairing on its own.
- f. If you wish to pair a second sensor, turn next sensor on while still in pairing mode on control module and repeat steps above. Once second sensor is paired, a second green LED will appear on the control module LED bar. To take the control module out of pairing press and release the red pairing button for five or more seconds in the side access panel. System returns to normal state and is now active.



3. TO UNPAIR SENSOR(S):

- a. On the control module, press and release the red pairing button (switches from normal operation to pairing mode)
- b. The control panels LEDs will display a yellow LED and start scanning, indicating that the unit is in pairing mode. Any green LEDs shown here indicate the number of paired sensors.
- c. Press and hold pairing button for five or more seconds. Green LED(s) will disappear which indicates sensor(s) has successfully been unpaired from the control module.
- d. Press and release red button again to take system out of pairing mode.

60 HZ OR 50 HZ

Sensors are shipped with a factory setting to detect 60Hz. Upon request, 50Hz presets can be set prior to shipping. **Customer may also switch between 60 Hz to 50 Hz by utilizing the switch (sw2) on the sensor.**

PLACEMENT AND INSTALLATION:

The almost unlimited types, sizes, and configurations of equipment on which Sigalarm products can be used, make it impossible to cover every potential installation configuration in the manual. However, the following explanation should help you understand general sensor placement considerations.

Place a single sensor at the highest point of the equipment. Where equipment has varying points that can be higher at any given time, multiple sensors should be installed at each of those points.

IMPORTANT: Sensors must not be obstructed by metal at any time. The sensors have an adjustable protection zone either default distribution or optional sub-transmission. Always install sensors with protection zones overlapping. Wireless Sigalarm systems are not appropriate for all types of equipment or every job-site. When in doubt consult a distributor or trained personnel.

MINIMUM APPROACH DISTANCE – MAD CONSIDERATIONS:

When installing multiple sensors on a piece of equipment, spacing between sensors should be based on the minimum approach distance or MAD. The distance between two sensors must not be greater than $1.75 \times \text{MAD}$. This ensures there are no gaps in protection between sensors. For example, if a minimum approach distance is 20 feet, then the spacing between sensors should be no more than 35 feet.

MOUNT THE SENSOR FOR OPTIMUM RECEPTION

After pairing the sensor(s) with the control module as previously instructed, when placing the sensor(s), ensure that it/they have the best possible line of sight back to the control module". Always verify the sensor status on the control module and that it is green "connected" after placement. Move equipment in all configurations to verify that the sensor never loses connection.

2.6 INSTALLATION OF THE EXTERNAL SPEAKER

An **exterior** weatherproof speaker is provided with each system to warn persons outside the equipment of danger. Place the speaker where it can easily be heard by ground crew but will not be damaged during equipment operation. Connect the blunt speaker wires to the supplied speaker cable conductor as follows:

- ▶ 15-LEH white cable (pin 11) to horn red conductor
- ▶ 15-LEH green cable (pin 12) to horn black conductor

WARNING: EXTERNAL SPEAKER HORN

Do not mount this speaker inside a closed cab.

2.7 TESTING THE INSTALLATION

1. Apply power to the unit and verify that the LED bar is lit, the (default) distribution LED indicator is lit, and the sensor status is green
2. Verify that the correct number of sensors is paired (Max 2 sensors; See section 2.5 "to pair sensors")
3. Before approaching live HV lines, use an AC power source such as an extension cord to activate the LED bar from normal status into both the caution (yellow) and danger (red) status
4. If auto shutdown is utilized, verify that the internal relay has stopped the boom movement.
5. Press resume operation to disengage the relay and move away from the power source
6. Verify that the internal and external speakers are operational
7. Test volume and adjust if necessary

NEED HELP? visit sigalarminc.com or Call **1 (800) 589-3769**

2.8 KEY FEATURES

1. Automatically set to warn of proximity to overhead high voltage distribution lines (7200-12,500 volts) at start-up.
2. No operator input is needed. The operator has the option to work around higher voltage lines by pressing the Sub-transmission button.
3. Optional shutdown
4. Easy to Install/Operate
5. Data logging
6. Removable Micro SD card format CSV file or excel
7. Connect up to 2 sensors
8. Internal and external speakers/ horn
9. 3 mounting options standard, square tube, or rail
10. USB interface for configuration and diagnostics
11. GPS receiver for time and location information and data logging

3. MENU DISPLAY IDENTIFICATION

3.1 HOME SCREEN / DETAIL VIEW

The home screen or detail view provides the central point of access for all the system's range of applications. It consists of the following sections:



1. Internal Speaker
2. Distribution graphic
3. Distribution button
4. Distribution LED indicator
5. Sub-Transmission graphic
6. Sub-Transmission button
7. Sub-Transmission LED indicator
8. Sensor Status LED indicator
9. Resume Operation button
10. LED Bar display indicates the AC field reported from the sensors
11. Side access port

4. OPERATION

4.1 WARNING : READ MANUAL BEFORE USE

The operator must fully understand how the SIG-LITE system functions, and its limitations before use. It is dangerous to operate any equipment directly beneath or above high-voltage power lines. If multiple lines are present, the SIG-LITE system should be set to the distribution/residential voltage line, and the operator must comply with any additional steps required OSHA precautions.

4.2 POWERING UP

The SIG-LITE is automatically set to distribution/residential lines (7.2kv-13.8kv) which will provide sufficient warnings near such overhead HV power lines.

4.3 KNOW MAD DISTANCE

Do not operate or rely on the SIG-LITE power line warning systems inside 10 feet under any circumstances.

4.4 CHANGING BETWEEN SET POINTS

If work is required anywhere near sub-transmission lines, the operator can select the alternate sub-transmission set point. This will reset SIG-LITE so that it works correctly near sub-transmission lines. If work is required around higher transmission voltages, if you are further away, SIG-LITE will alarm whether these lines are in either distribution or sub-transmission mode.

4.5 OPERATING IN THE DISTRIBUTION POWER LINE SETTING

This is the system's default setting and is programmed to provide warning to distribution power lines between 7.2 and 13.5Kv at around 15-20 feet away. As you approach these lines, SIG-LITE should give visual and audible CAUTION (yellow) and DANGER (red) warning notification.

4.6 OPERATING IN THE SUB-TRANSMISSION POWER LINE SETTING

At any time the operator can switch to the Sub-transmission setting to work around higher voltage lines. This setting should never be utilized to try and work near distribution lines. If the operator receives a warning in either mode, the operator should stop movement and evaluate their situation.

Once the operator identifies the source of the warning, they should immediately reposition the equipment away from the AC overhead power lines until the SIG-LITE returns to a Safe Reading.

4.7 OPERATING WITH A CAUTION (YELLOW) NOTIFICATION

If the operator moves toward the AC overhead power line and the V/m increases, then the SIG-LITE will go from a SAFE (green) state to a CAUTION state.

The operator should identify the power source and reposition the equipment to stay out of an area that triggers a CAUTION notification.

Once the operator identifies the source of the warning, they should immediately move the equipment away from the AC overhead power lines until the SIG-LITE returns to a SAFE state.

4.8 OPERATING WITH A DANGER (RED) NOTIFICATION

If the SIG-LITE is in the CAUTION state and the operator continues to move toward the AC overhead power line and the V/m increases, then the SIG-LITE will go to a DANGER notification.

The operator should immediately stop the movement of the equipment and identify the power source. Reposition as necessary to stay safely clear of overhead high voltage lines.

Once the operator identifies the source of the warning, they should immediately move the equipment away from the AC overhead power lines until the SIG-LITE returns to a SAFE state.

4.9 SENSOR STATUS LED

This LED remains green as long as the wireless sensor remains paired and/or in operation.

4.10 VOLUME ADJUSTMENT

Simple plus-minus buttons allow the operator to adjust the speaker volume.

4.11 OPERATING WITH AUTO SHUTDOWN INSTALLED

SIG-LITE has internal relays that can be used in many different ways. Some employers install a system in such a way that the equipment will stop moving in a CAUTION or DANGER state. This is referred to as "Auto-Shutdown".

In the event you are in one of these two states, and where equipment movement has been interrupted, the operator must use the resume movement override feature in order to disable the lockout and reposition the equipment.



AUTO-SHUTDOWN IS NEVER RECOMMENDED FOR EQUIPMENT MOVING A LOAD.

4.12 RESUME MOVEMENT

This button allows the operator to resume movement by closing the circuit to the hydraulics for a period of 7 seconds (if auto shutdown was installed on the machine).

4.13 OPERATING NEAR INTERSECTING POWER LINES

Intersecting power lines, especially of different voltages, can create complex E-fields. **DANGER:** Extreme caution should be taken when working around these conditions. Use additional protection whenever possible, such as a dedicated spotter.

NEED HELP? visit sigalarminc.com or Call **1 (800) 589-3769**

5. SPECIFICATIONS

Controller

- ▶ Supply voltage 12-24 vdc
- ▶ Size: 6 ½" X 5" X 2 ¼"
- ▶ Internal speaker db 2W
- ▶ Bluetooth module 2.4Ghz radio
- ▶ Operating temperature range -20 to +85C
- ▶ Storage temperature range -20 to +85C
- ▶ Humidity 0-100%

Sensor

- ▶ Operational voltage- 3.7v lithium-ion battery
- ▶ Size 5 ¾" X 2 ½" X 1 5/8th
- ▶ Bluetooth module 2.4Ghz radio
- ▶ E-field detection range (Electric Field 60 Hz or 50Hz) selector switch located on board (default is 60Hz)
 - ▶ This system is designed for detecting AC voltages of 7,200v or higher at approximate distances of 10ft-200ft. SIG-LITE should not be relied upon to provide a warning for voltages less than 7,200v AC or closer than 10ft.
- ▶ Operating temperature range 0 to 45 degrees C
- ▶ Storage temperature range -20 to +60 degrees C
- ▶ Max Range between sensor and controller 27m

External weatherproof speaker/horn Speco technologies SPC-5P 8 ohms

- ▶ Power Rating 15W max
- ▶ Sensitivity 105db/1W/1M
- ▶ Dimensions 5" X 5"

6. TROUBLESHOOTING

WILL NOT POWER UP:

- ▶ Check power connections and supply voltage.

NO INTERNAL SPEAKER SOUNDS:

- ▶ Check amps supplied meet speaker min.

NO EXTERNAL SPEAKER SOUNDS:

- ▶ Check connectivity.
- ▶ Check amp supply meets speaker min.

SENSOR STATUS INDICATOR, NOT LITE:

- ▶ Check input power connections.

SENSOR STATUS INDICATOR BLINKING RED:

- ▶ Check the connection to the correct number of sensors.

LED BAR NOT ILLUMINATED:

- ▶ Check power supply.

7. FCC COMPLIANCE STATEMENT

This device complies with part 15 of the FCC Rules. Operation is subject to the following two conditions:

- (1) this device may not cause harmful interference, and
- (2) this device must accept any interference received, including interference that may cause undesired operation.

CAUTION: The grantee is not responsible for any changes or modifications not expressly approved by the party responsible for compliance. Such modifications could void the user's authority to operate the equipment.

NOTE: This equipment has been tested and found to comply with the limits for a Class B digital device, pursuant to part 15 of the FCC Rules. These limits are designed to provide reasonable protection against harmful interference in a residential installation. This equipment generates, uses, and can radiate radio frequency energy, and if not installed and used in accordance with the instructions, may cause harmful interference to radio communications. However, there is no guarantee that interference will not occur in a particular installation. If this equipment does cause harmful interference to radio or television reception, which can be determined by turning the equipment off and on, the user is encouraged to try to correct the interference by one or more of the following measures:

Reorient or relocate the receiving antenna.

Increase the separation between the equipment and receiver.

Connect the equipment into an outlet on a circuit different from that to which the receiver is connected.

Consult the dealer or an experienced radio/TV technician for help.

This equipment complies with the FCC radiation exposure limits set forth for an uncontrolled environment. This equipment should be installed and operated with a minimum distance of 20cm between the radiator and all persons. This transmitter must not be co-located or operating in conjunction with any other antenna or transmitter.

8. CANADIAN COMPLIANCE STATEMENT

This device contains license-exempt transmitter(s)/receiver(s) that comply with Innovation, Science and Economic Development Canada license-exempt RSS(s).

Operation is subject to the following two conditions:

- (1) This device may not cause interference.
- (2) This device must accept any interference, including interference that may cause undesired operation of the device.

L'émetteur/récepteur exempt de licence contenu dans le présent appareil est conforme aux CNR d'Innovation, Sciences et Développement économique Canada applicables aux appareils radio exempts de licence. L'exploitation est autorisée aux deux conditions suivantes:

- (1) L'appareil ne doit pas produire de brouillage;
- (2) L'appareil doit accepter tout brouillage radioélectrique subi, même si le brouillage est susceptible

NOTE: Afin d'assurer la conformité aux exigences de la FCC en matière d'exposition aux radiofréquences, aucune modification de l'antenne ou de l'appareil n'est autorisée. Toute modification de l'antenne ou de l'appareil pourrait avoir pour conséquence que l'appareil dépasse les exigences en matière d'exposition aux radiofréquences et annule le droit de l'utilisateur de faire fonctionner l'appareil.

9. RELAY OUTPUTS DIAGRAM

Relay outputs:

Relay 1 is intended to stop movement when AC is detected. Relay 1 is RESET (Not Normal) when threshold for relay 1s setting is exceeded. Threshold is a configurable parameter Relay 1 is RESET when operator presses Resume Movement. Once Resume Movement has been pressed relay 1 will go to SET (Normal) again until the resume delay has expired, then will go RESET (Not Normal) if still above the threshold.

Relay 1 will go RESET (Not Normal) when Vehicle Switched Power is turned off

Relay 1 will go RESET (Not Normal) when one or both sensors loose connection to control module

Relay 2 is intended for external alert such as a strobe light. Relay 2 is SET when threshold is exceeded. Threshold is a configurable parameter . Relay 2 is RESET when reading is below threshold .

Note: Relays can switch up to 1 Amp Current Max

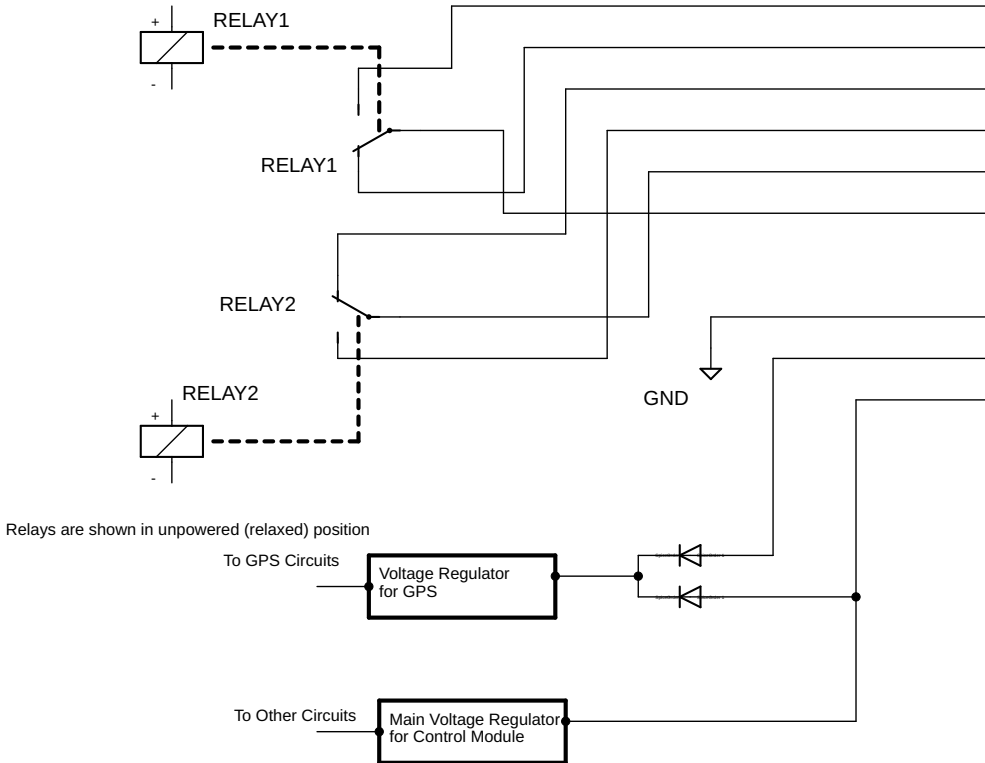

NOTE: Signaling shown for Firmware Version 0.11 or higher

<h1>SigAlarm</h1>	
SigAlarm Light Control Module Internal Signal Connections	
TITLE: Int_Relay_connects	
Document Number:	REV: Rev C
Date: not saved!	Sheet: 1/1

12 Pin Bulkhead Connector

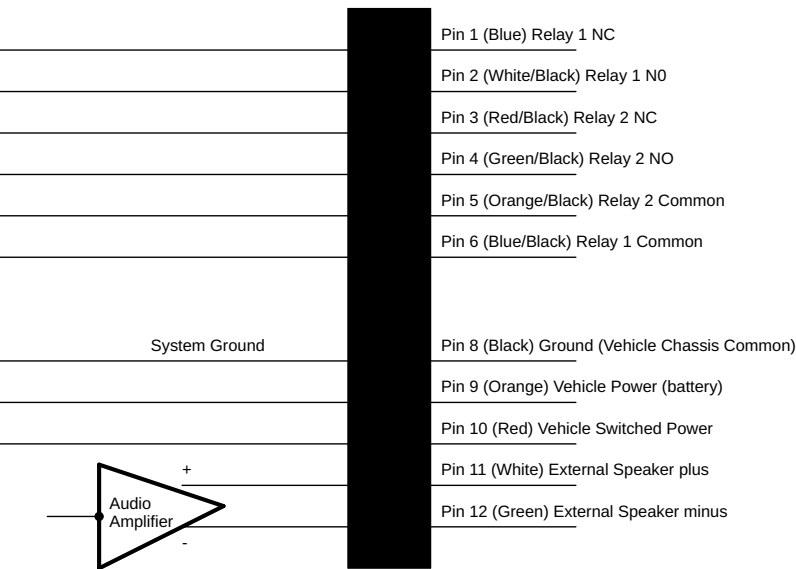

- Pin 1 (Blue) Relay 1 NC – Relay 1 movement stop, contact OPEN To Stop
- Pin 2 (White/Black) Relay 1 NO– Relay 1 movement stop, contact CLOSE To Stop
- Pin 3 (Red/Black) Relay 2 NC
- Pin 4 (Green/Black) Relay 2 NO – Connect to Strobe/Siren contact CLOSE On Alarm
- Pin 5 (Orange/Black) Relay 2 Common – Relay 2 intended for external alert / strobe
- Pin 6 (Blue/Black) Relay 1 Common – Relay 1 intended for movement stop
- Pin 7
Not Used - no wire
- Pin 8 (Black) Ground (Vehicle Chassis Common) – MUST be connected
- Pin 9 (Orange) Vehicle Power (battery) – optional – used to keep GPS active/locked
- Pin 10 (Red) Vehicle Switched Power (main power) – MUST be connected
- Pin 11 (White) External Speaker plus – 10 watt audio output for external speaker
- Pin 12 (Green) External Speaker minus

10. SENSOR SELF-TEST PROCEDURE

The self-test simulates a 60 Hz AC power signal to verify that the receiver circuits are functioning, running automatically at power-up or when the reset button is pressed on the sensor. It takes approximately 10 seconds to complete.

Refer to the image (top right) showing the RESET and PAIR buttons on the sensor board.

Self-test failure: Solid blue + two quick flashes every two seconds.

Self-test pass: Quick flash every five seconds.

Firmware version: Blue LED flashes version number at startup (e.g., five times for v0.05).

WHEN TEST PASSES:

LEDs light from low green to high red, and then return to green.

WHEN TEST PASSES:

No signal is sent from sensor to activate LEDs. Control module status LED flashes red.

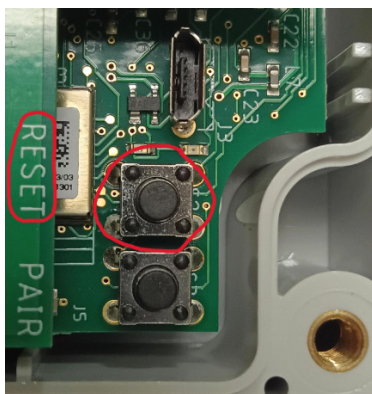

The self-test confirms proper sensor and receiver functionality, while the firmware version is verified through LED flashes. No control module firmware update is required.

TO DOWNLOAD RMA FORM VISIT:

SIGALARMINC.COM/RMA



SCAN TO DOWNLOAD FORM

Customers wishing to return units to Sigalarm for any reason must complete the Return Material Authorization (RMA) form before returning the units. This includes both Warranty and Out of Warranty repairs.

Send unit to 4150 St. Johns Pkwy, Ste 1002 Sanford FL 32771
Attn: Warehouse Service Technician.





WE'RE IN THE BUSINESS OF **SAVING** **LIVES**

WARNING: Read the entire manual before installing or operating this Sigalarm product. Failure to follow these instructions and safety precautions could result in serious injury or death. Keep this manual near the equipment where SIG-LITE has been installed.